

High quality aluminium welding – a key factor in future car body production

by Lars-Ola Larsson, and Niclas Palmquist, Volvo Cars, Advanced Manufacturing Eng. and Johnny K Larsson, Volvo Cars, Advanced Body Engineering

The automotive industry is constantly looking for new ways to reduce fuel consumption. This is not only an individual concern for the car customer but also an environmental question on a more global level. When it comes to meeting these environmental requirements, the contribution from body design and manufacturing engineers lies in the field of weight savings.

Due to its low specific weight and good recyclability, aluminium stands out as a natural materials candidate and it is therefore self-evident that an increased amount of aluminium is expected to be seen in future car bodies.

To be well prepared for the introduction of new legislative demands, introduced in order to avoid the subversion of our planet, the Volvo Car Corporation has for many years been conducting broad-based research programmes on aluminium car body structures. To obtain the optimum performance from a structure of this kind, it generally has to be manufactured in a manner that differs from the current steel uni-body solutions. In this context, the use of advanced joining techniques plays an important role and a great deal of interest has therefore recently focused on aluminium joining techniques.

The results of some of these laboratory and semi-production trials are presented in this article. Three main subjects are reviewed. They are:

- Pulsed MIG welding of structural parts
- Aluminium tailored blanking
- Laser stitch welding of an all-aluminium bonnet

At the end of the article, the authors attempt to analyse the future use and development trends for the joining and assembly of automotive aluminium structures.

Pulsed MIG welding of structural parts

In order to meet the demand for future lightweight designs, such as aluminium space frame structures, a great deal of effort has been put into the area of pulsed MIG welding. This is a flexible joining method which can be used with single-sided access. In car production, MIG/MAG welding has normally been restricted to component parts and tack welding in body shops.

When both “new” materials and “new” joining techniques are introduced in car body shops, a large

number of basic tests have to be conducted. From a welding point of view, these tests focus on the influence of:

- Filler wires and shielding gases
- Surface conditions and the type of lubricants on the base material
- Welding positions and gap sizes
- Node joint design – enabling robust robotic welding of sheet thickness combinations in the joint set-up
- Optimal weld length and sequences
- Equipment; robot, wire feeding systems and welding power source

The design strategy of the Volvo Car Corporation is to avoid castings, which means that there are basically three typical joint designs – profile to profile (1), sheet to profile (2) and sheet to sheet (3) combinations, see the following presentation.

Due to the relatively high energy input, MIG welding is mainly restricted to the profile to profile combination and is only be used in the two other cases mentioned here if it is not possible to use laser welding, riveting or resistance spot welding.

The basic equipment and weld set-up in the following 2D and 3D structures has been:

- KUKA Functional Package with (Quadro Drive) push-pull system
- Pure argon shielding gas supply
- AlSi12 filler wire with a diameter of 1.2 mm

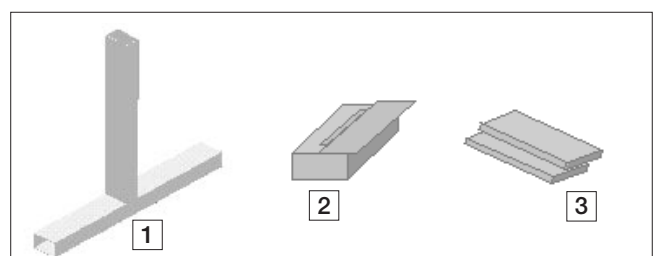

Figure 1. Typical joint design configurations.

Structural 2D welding

A large number of simplified generic frames have been welded and thoroughly examined and tested. In the frame, extruded aluminium profiles of AA6060-T6 alloy with a thickness of 2.0 and 3.0 mm have been used. All the welding has been performed robotically and turning units have been used to evaluate different welding positions, welding sequences and clamping principles (see the simulations in the following figure)



Figure 2. Simulation results from welding access control in different welding positions.

The majority of the joints were fillet joints but some butt joints were also tested. See some typical cross-sections in Figure 3. Note the pores in the welds and the overfill of the butt joint. Pore formation can be kept to a minimum if the parts are washed and pickled just before welding. On the other hand, too complicated a pre-treatment process is costly.

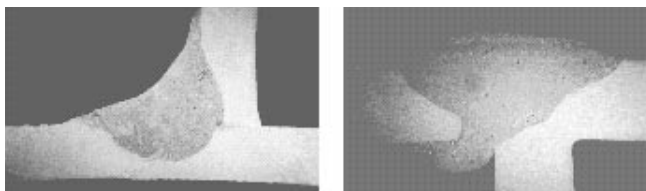

Figure 3. Typical cross-sections of a horizontal fillet weld and a flat butt joint.

In order to achieve robust welding quality, butt joints should be avoided, mainly because of their sensitivity to gaps. The synchronous welding of frames with two robots has also been tested.

The recording of measurements over a large number of distortion sensors, positioned over the generic frame, has shown that the overall distortion can be reduced by more than 50% when using symmetrical welding. In addition, even less distortion was achieved when optimal clamping and welding sequences were tested. See principal test set-up in the Figure 4.



Figure 4. Principal test set-up for symmetrical welding of generic frames.

Structural 3D welding

A concept study was originally started in order to evaluate the production of aluminium space frames in the existing S/V70 and S80 body shops. This involves the robotised welding (production like) of the aluminium car body structure in the existing Volvo pallet systems. The space frame structure and the pallet system are divided into floor, sides and roof frames/pallets which are positioned, fixed and joined at a separate station called MPF, Multi-Pallet Framing. See Figure 5 taken from the pilot building in a manual MPF station.

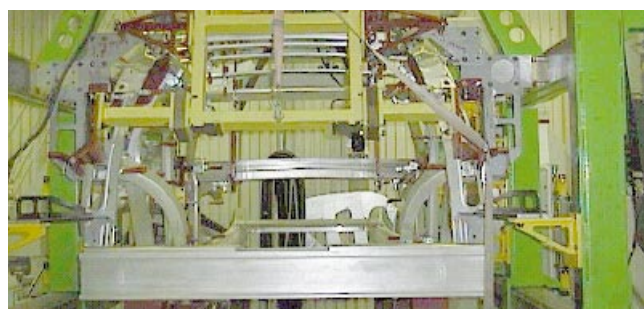

Figure 5. Rear view of the concept car in the manual MPF station.

This study involved many technical disciplines, such as geometry assurance, surface preparation for joining, joining technology, manufacturing engineering and suitable surface treatment for the paint shop. From a joining perspective, evaluations were carried out in order to study the influence of:

- Existing clamping and tolerance situation with hydroformed parts
- Different welding sequences and welding positions
- Different joint geometry designs

A 3D joint of the A-pillar in a side palette is shown in Figure 6. It is important to have good joint preparation with very low cutting tolerances in order to keep gap sizes to a minimum.



Figure 6. Detailed study of a 3D MIG joint and the corresponding result after welding.

In parallel to the concept building, comprehensive work has been carried out in the field of equipment development and quality assurance. Different robotic functional packages and in-process monitoring systems have been evaluated and these activities are still in progress. Many activities are also on-going in the field of NDT (Non Destructive Testing).

Laser welding of tailored blanks in aluminium

Over the years, the tailored blanking of steel sheets has become more and more popular and today this method

is widely used within the automotive industry all over the world. In the case of certain applications, the benefits of reduced material weight and total costs outweigh the increased cost of the joining process and the forming tools, which justifies this investment. The next step is to use the knowledge acquired from tailored blanking in steel and adapt it to aluminium.

Relatively simple welding equipment can be used for tailored blanking operations as welding is performed in two-dimensional form. In most cases, the welding is done with a gantry system for handling the mirror in combination with a high-power CO₂ laser of 5-8 kW, but, in the case of aluminium tailored blanking, Nd:YAG laser welding is an alternative due to the higher absorption of the Nd:YAG laser light. Less power can then be used to reach the same weld speeds and less heat is put into the material. Experience has shown that both Nd:YAG- and CO₂ lasers can be used for aluminium tailored blanking [1].

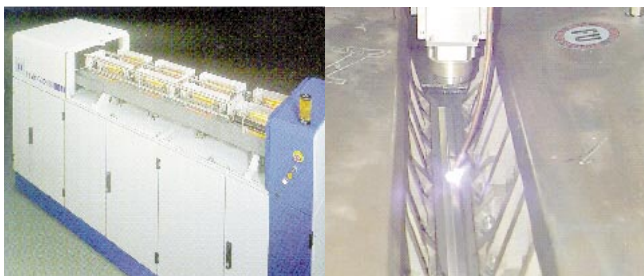

Figure 7. 4 kW laser source and set-up with linear fixture for clamping.

When welding aluminium, a power density of at least 1 MW/cm² on the workpiece is required, otherwise the laser beam will reflect on the surface of the material. For a stable welding process, and to perform keyhole welding, at least 2 MW/cm² is required, due to the high reflection and heat transfer of aluminium. Previously, aluminium has only been weldable when using focal lengths of about 100 mm, projecting a very small spot on the material to maintain the required power density. The increased beam quality and output power of today's Nd:YAG lasers make it possible to weld aluminium with up to twice the focal length, 200 mm. Advantages include the reduced contamination of the sensitive lenses on the welding equipment, reduced sensitivity to fluctuation in height, allowing cheaper guidance systems, and increased access. A comparison

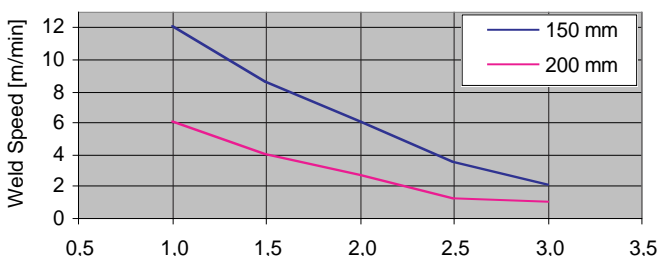

Figure 8. Weld speed as a function of focal length and material thickness. Material AA-5052, welded from stepside [2].

between weld speeds for different focal lengths can be seen in Figure 8.

Too short a focal length results in a great deal of spatter and an oxidised root side. Defocusing the focal point does not stabilise the welding process. Due to the aggressive welding process and the short distance, the protection glass of the optics contaminates quickly

As different from steel, aluminium normally displays a decrease in strength after welding. Previous investigations have shown that the tensile strength of 5000-series (Al-Mg) aluminium alloys can also be obtained in the weld, but at a reduced elongation [3]. For heat-treatable alloys, like the 6000-series (Al-Mg-Si), the weld zone normally shows a decrease in tensile strength to 70-90% or less than that of the base material [4]. The condition of the material prior to welding has also been shown to be critical for the strength obtained after welding [5]. Material in the soft condition, normally 5000-series, does not display any difference in Rp and Rm before and after welding, while 6000-material in the tempered condition T4 shows a decrease in Rm to 65-85% of the base material, while Rp is unaffected, and material in T6 condition shows a decrease to 65-85% in both Rm and Rp.

In the case of tailored blanking, material from both the 5000- and 6000-series alloys is of interest, depending on the final application. The differences between the two alloy types are the content of the alloying elements magnesium and silicon. For the materials normally used within the automotive industry, the magnesium content of the Al-Mg alloys is generally in the range of 1.8-3.0%, while in the Al-Mg-Si alloys the content of the elements is 0.4-0.6% for magnesium and 0.9-1.2% for silicon. The mixture of magnesium and silicon in 6000-series alloys has been shown to be sensitive to cracks in the weld zone.

The laser welding of tailored blanks is normally performed in a butt weld configuration with sheets of different thickness or material quality. The welding orientation of the materials used in the blank can vary. Welding is either performed on the flush surface, orienting the step of the different thickness downwards, or on the step side. Choosing one or the other influences the weld quality and the achieved weld speed [2].

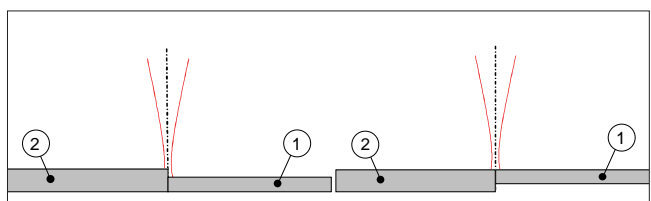

Figure 9. Welding position step side versus flush side.

Depending on the thickness combination, the difference in weld speed between the flush side and the step side increases as the difference in thickness increases, see the following figure. On the other hand, the top and root bead appearances are much smoother when welding on the step side, see the following figure.

Aluminium alloy	Condition	Rp [Mpa]	Rm [MPa]	Thickness
AA-5052 (AlMg2.5)	O	110	190	1.0–3.0 mm
AA-5754	O			1.0–3.0 mm
AA-6016 (AlMg0.4Si1.2) (Ac120)	T4	105	205	0.8–2.5 mm
Ecodal 608 (AlMg0.8Si0.9)	T4	124	235	0.8–2.0 mm
AA-6111	T4			0.8–2.5 mm

Table 1. Data for typical aluminium materials for the automotive industry.

Alloy	Si	Fe	Cu	Mn	Mg	Cr	Ti	Zn
AA-5052	< 0.25	< 0.40	< 0.10	< 0.10	2.2–2.8	< 0.05	< 0.05	< 0.10
AA-5754	< 0.40	< 0.40	< 0.10	< 0.50	2.6–3.6	< 0.30	< 0.15	–
AA-6016	1.0–1.5	≤ 0.50	≤ 0.20	≤ 0.20	0.25–0.60	≤ 0.10	≤ 0.15	≤ 0.20
AA-6111	0.7–1.1	< 0.40	0.5–0.9	0.15–0.45	0.5–1.0	< 0.10	< 0.10	< 0.15
Ecodal 608	0.7–1.0	< 0.50	< 0.25	< 0.40	0.60–0.95	< 0.30	< 0.30	< 0.50

Table 2. Chemical composition for the alloys from Table 1.

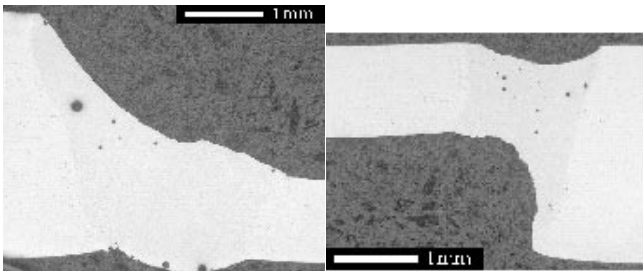

Figure 10. Cross-sections of welds welded from the step side and flush side.

When welding thicker to thinner materials from the step side, the seam appearance is normally improved if the laser beam is positioned with an offset towards the thicker material. The thicker material needs more heat to melt and can also serve as extra material to smooth the weld. Depending on the thickness, an offset of 0.1 to 0.2 mm should be used.

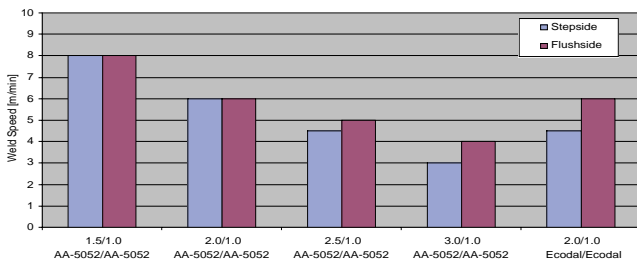

Diagram 1. Weld speed as a function of seam orientation.

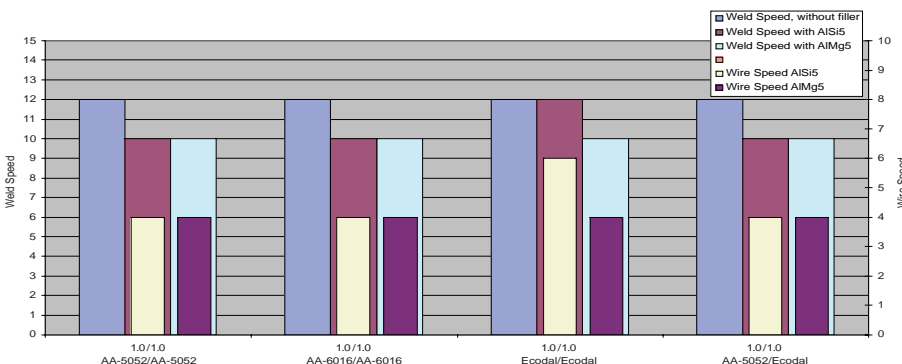

Diagram 2. Wire and welding speed for different material combinations and filler wire materials.

Simple bending tests on 6000-alloys welded with filler wire have shown failures in the base material and not in the weld, as is the case without filler. Tested combinations of different materials with filler wire have shown an increase in static strength and especially in samples welded with AlMg5 wire, in some cases as high as or higher than the base material .

To test the formability of a blank, spheres can be formed. The resulting force during forming and the displacement before a crack in the blank determines the formability. The cracking behaviour of the blank also defines the forming properties of the joint, see the following figure.



Figure 11. Cracking behaviour of welded aluminium blanks.

Beamsplitting, or twinspace, is a way to split the laser beam into two points, close to one another, at the workpiece. The spots can either be diverted in the longitudinal direction of the laser beam, or transversely in the horizontal plane, see the following figure. When diverted transversely in the same horizontal plane, the points can be oriented in any direction to the weld direction and with the opportunity to balance the energy distribution between the two points – for example, allowing different energy to be focused on different material thicknesses. Experience has shown that transverse beam splitting reduces the weld speed to approximately half the speed with normal optics.

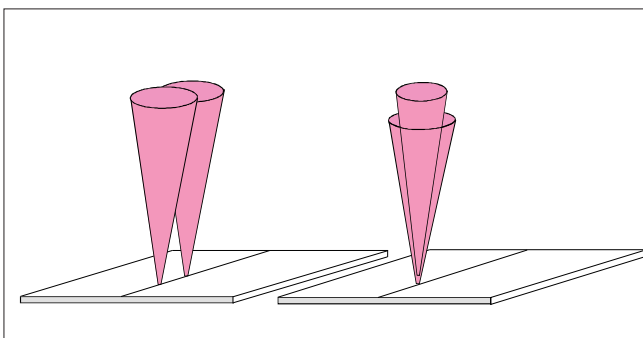

Figure 12. The principle of the two twinspace techniques, in the same horizontal plane (left) and in the same vertical plane (right).

When the beam is diverted in the longitudinal direction, the energy is evenly distributed between the two spots and with a distance of about 3.5 mm between them. In this case, the distance can also be changed by changing the focal length. Splitting the beam in this direction does not have any effect on the weld speed compared with normal optics when welding in thin ma-

terials, but a slight decrease can be seen, together with a more oxidised root, when welding in thicker material. The depth of focus for this kind of optics is approximately 4 mm.

For laser welding in aluminium., helium is the most frequently used shielding gas, but welding can also be performed without shielding. The drawback of not using any shielding gas is a more intense weld process with an increased amount of spatter. The advantage is an increased weld speed of up to 40% depending on the material thickness.

Laser stitch welding of an all-aluminium bonnet

The production laser welding test on the Volvo 960 aluminium bonnet was a continuation of a joint venture between Volvo, BMW, Porsche and Mercedes Benz. It was initially designed to develop new types of fixation equipment for single-sided Nd:YAG laser processing.

Taking account of the fact that the Nd:YAG laser has a more favourable wavelength than the CO₂ laser when it comes to welding aluminium, the project management decided to run a limited production test on a suitable aluminium component. One necessary condition for this production test was to have an opportunity to integrate the test equipment in the production line and to have possible back-up from standard RSW (Resistance Spot Welding) equipment. The production layout of the bonnet for the 960 luxury model created both these opportunities. The production test was carried out as standard sub-assembly production with the opportunity stop production for evaluations and adjustments of welding parameters [6].

The laser welded application consisted of the inner bonnet itself and five additional reinforcements for hinges/gas struts, locks and safety latch, which are normally joined together using resistance spot welding. The material specification for the different parts can be found in Table 3 and the complete inner bonnet is illustrated in Figure 13.

Part	Alloy	Thickness (mm)	Pickled	Number
Bonnet, inner	AlMg2Mn0.3	1.0	Yes	1
Hinge/gas strut reinforcement	AlMg2.5	2.0	Yes	2
Lock reinforcement	AlMg2.5	1.5	No	2
Safety latch reinforcement	AlMg2.5	1.5	Yes	1

Table 3. Parts specification for the 960 bonnet, inner section.

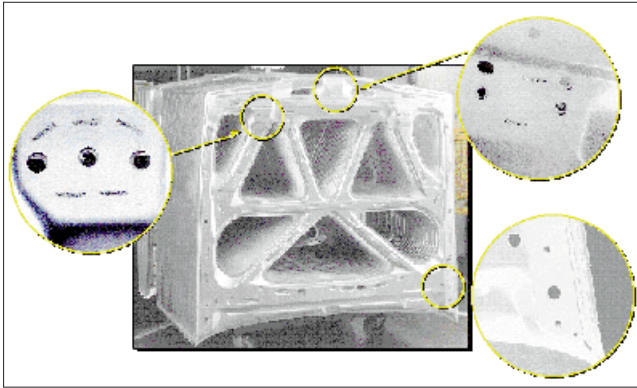

Figure 13. Laser welding of the Volvo 960 Series aluminium bonnet.

An Nd:YAG laser cell was built in the Volvo Olofström plant [Figure 14], introducing a 2kW Rofin Sinar Nd:YAG laser together with a six-axis KUKA articulated-arm robot with a load-carrying capacity of 125 kg. The size of the robot was chosen so that it would be able to carry both the welding head with integrated beam delivery fibre optics and the so-called "Picker unit". This is a two-axis, NC-controlled, movable table, controlled by the robot control unit and acting as the seventh and eighth axis of the robot [Figure 15]. The robot positions the "Picker unit" at the starting point of the welding path, after which the "Picker" moves the welding head during the welding operation, while the robot is fixed. Using the two "Picker feet", controlled pressure is applied to the sheets in order to control the gap between the sheets that are being welded together [7].

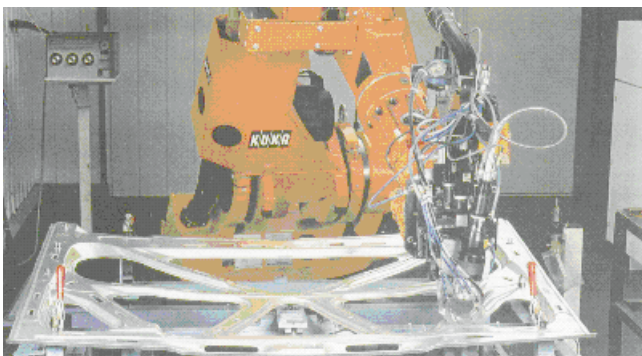

Figure 14. Flexible Nd:YAG laser welding cell at the Volvo Olofström pressing plant.

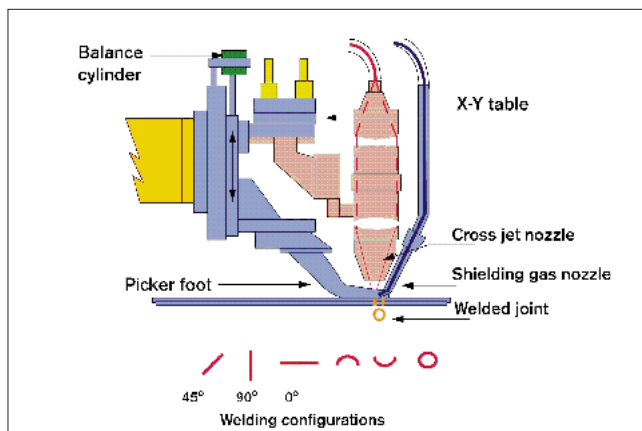

Figure 15. Concept of the "Laser Picker" welding head.

The cell had the shape of a completely closed safety cabin, inside which the welding took place. The cooling unit and the control cabinets for the robot and the laser, as well as the shielding gas battery, were outside the cabin. Loading and unloading was done manually from outside the cell through an opening that was closed with a sliding door during the welding operation. The parts were placed on a tilting fixture, which was in a vertical position during loading and unloading and in a horizontal position during welding.

The reinforcements were welded to the inner structure of the bonnet with 32 18-mm long weld stitches using the Laser Picker technique. The average power was 1.8 kW when the laser was operated at a frequency of 50 Hz. The initial welding speed was 0.9 m/min, which could be increased during the cycle, due to the heat conductivity of the material, up to 1.5 m/min. A sensitive mixture of helium and argon as the shielding gas proved necessary to obtain satisfactory weld quality. The ideal mixture ratio proved to be 90% helium to 10% argon. The shielding gas was supplied through a separate hose at 11 l/min to the gas nozzle situated close to the laser focal point.

To prevent aluminium spatter from the welding process sticking to the covering glass which protects the focusing lens, a cross-jet device had to be developed [Figure 16]. This unit is placed under the cover glass and creates an air stream (air pressure 1.2 bar) which, on the inside, crosses the opening of the laser nozzle. The avoidance of contamination of the covering glass is essential to maintain stable welding conditions and thereby the required weld quality. However, due to the short focal distance of 120 mm, spatter and dust from the welded material still stuck the outside of the water-cooled laser nozzle and inside the cross-jet outlet. For this reason, a small rotating brush had to be included for the auto-cleaning of the nozzle after each work cycle. The total cycle time in the cell was 3 minutes 20 seconds, of which approximately two minutes were real welding time.

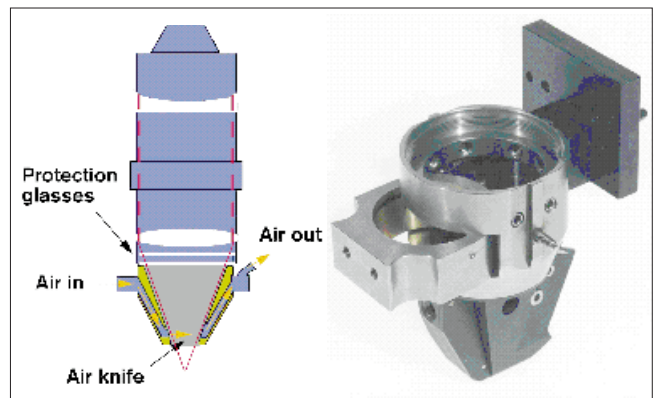

Figure 16. Cross-jet nozzle for the protection of laser optics.

In order to guarantee the quality of the welded parts before delivery, some bonnets were checked by destructive testing at a frequency of one per 50 bon-

nets Using a hammer, chisel and tongs, the joint was stressed until it broke. The weld was regarded as OK if the fracture occurred in one of the sheets and not in the weld itself. During the production period, a comparison was made with conventionally spot-welded bonnets. The results of 87 comparisons were as follows:

- 42 laser-welded bonnets were regarded as better than ordinary spot-welded ones
- 42 laser-welded hoods were regarded as equal to ordinary spot welded ones
- three laser-welded hoods were regarded as worse than ordinary spot welded ones

In order to perform a more accurate follow-up of joint quality, laboratory tests were carried out as an integrated part of the production test. For each bonnet, randomly selected for this quality check, a cut was made perpendicular to the welding direction for every one of the 32 weld stitches. These cross-sections were then analysed in a microscope and the occurrence of cracks and pores was determined, as well as the penetration width and depth.

It was noted that a certain number of pores occurred. This was mainly due to disturbances in the welding process and was not seen as a vital problem as no pores could be found in half the bonnets examined. In some of the bonnets, cracks inside the welds were discovered. It is our experience that this can be avoided by improving the mating of the surfaces that are going to be welded together. Because, even if the gap between the sheets is closed by the pressure of the "Picker feet" during welding, there are increased tensile stresses on the weld during cooling. However, the cracks that were observed did not have any serious effect on the strength of the joint.

The average penetration width was 1.40 mm, ranging from 1.00 mm to 1.70 mm. One reason for this variation is the continuous decrease in output power due to wear to the arc lamps and the action taken to counteract this, such as decreasing the welding speed, adjusting the focal length and replacing the lamp. Another reason for penetration width variations is the cross-jet problem described earlier, resulting in unsteady output power because of dust and spatter contaminating the cover glass. Figure 17 below shows the penetration width variations. Point 1 shows the width just before a planned decrease in speed because of arc lamp wear. Point 2 shows the width immediately after replacing all the arc lamps with new ones. The extreme value for point 3 is explained by the mistake of welding without helium shielding gas. The average penetration depth into the reinforcements, including all 32 weld stitches on all the bonnets measured, is 0.73 mm, ranging from 0.42 mm to 1.19 mm. The reasons for the depth variations are similar to those for the width variations earlier described.

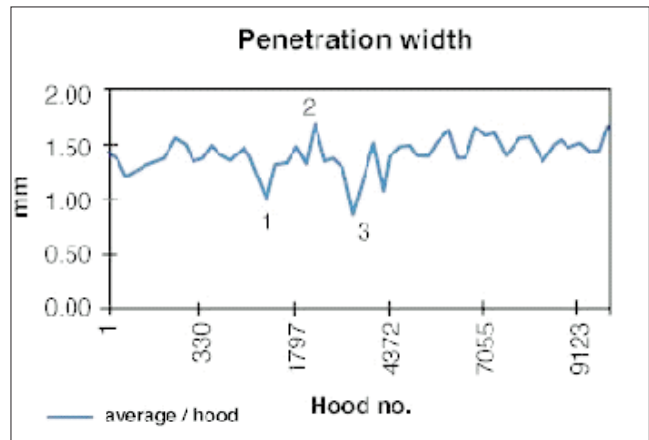

Figure 17. Penetration width variation.

This test was limited to a six-month period during which 100-120 bonnets were produced in each working shift. A total of 10,000 bonnets were produced during this time. If an availability calculation is performed, based upon the number of parts mentioned above and a cycle time including 98% productive time (low-frequency activities are then regarded as planned maintenance outside ordinary working time), the technical availability is estimated at 95.7% and the technical efficiency at 99.6% []. The number of stops during the production test were 37, representing a total stoppage time of 1,445 minutes. The most frequent stops were due to fibre monitoring alarms (eight times) and exploded laser lamps (five times). The longest stops occurred when a broken fibre or hose had to be replaced.

It is difficult to compare the laser-welded solution with the traditional spot-welded one, as the first one was a test installation that was not fully optimized. On the other hand, what can be compared are the figures relating to non-productive activities per part. These account for 12 seconds for the laser welding, whereas the corresponding time for tip dressing and cleaning in the RSW case, for example, is 15 seconds. This means that the relationship between the productive cycle time and the total cycle time in the fully automated production spot welding station is 88%.

The yearly running cost for this installation is calculated in Table 4. It is based on a one-shift operation during the daytime and indicates a capacity of 27,000 produced parts a year.

	Total cost (SEK)	Cost per part (SEK)	Cost per year (SEK)
Shielding gas	38,600	3,86	104,220
Electric power	7,500	0,75	20,250
Spare parts	87,250	8,73	235,710
Manpower, production	175,000	17,50	472,500
Manpower, maintenance	7,000	0,70	18,900
Stoppage cost	8,400	0,84	22,680
TOTAL	323,750	32,38	874,260

Table 4. Summary of running costs.

The running costs for the laser-welded inner bonnet ended up at SEK 32.38, but once again it must be stressed that, as this was not an optimized installation, the cost is hardly relevant, as more than half of it is accounted for by manpower costs in connection with the manual loading and unloading operations.

Summary and future outlook

In previous body engineering, virtually only one material was used, namely mild steel. Due to customer requests for improved properties in areas such as safety, reliability, driving performance, NVH (noise, vibrations, harshness) and so on., new materials have successively been introduced into the car body to meet these demands.

In the future, we can expect a further demand for increased fuel efficiency, as the resources for natural, fossil-based fuels are limited. Moreover, the pollution and contamination of the environment, originating from the emissions from combustion engines, have a destructive effect on society.

Different steps can be taken to improve fuel efficiency and reduce toxic emissions, but, if we look at the BIW alone, its contribution comes from the field of weight saving. The largest weight savings can be achieved if materials selection, body concept and joining methods are developed in an integrated process. Aluminium is a natural candidate due to its low specific weight and good recyclability and it is therefore self-evident that an increase in the amount of aluminium can be expected in future car bodies. Different aluminium alloys which are appearing in different shapes, such as sheets, extrusions, castings and hydro-formed parts, will have to be joined together. To maintain the excellent car body properties that our customers expect, it is crucial that the joining methods that are chosen meet the automotive industry's rigorous demands in areas like process speed, availability (up-time) and quality turnout.

The examples presented in this article are just a couple of the activities that have recently been run at Volvo in the field of aluminium joining. In the newly established Volvo Joining Centre, a comprehensive test plan has been outlined to further increase the knowledge of aluminium joining among design and production engineers and production personnel. When it comes to other activities scheduled for this year with the aim of improving skills and expertise, the following research areas can be mentioned:

- Resistance spot welding utilizing adaptive weld parameter control
- Plasma and hybrid welding techniques
- Evaluation of mechanical joining techniques such as punch riveting
- Adhesive bonding systems, including optimum surface pre-treatment and testing of long-term behaviour under environmental and mechanical loading.

References

- [1] Carlsson, T., Palmquist, N., "Laser Welding of Aluminium Tailored Welded Blanks, from Laboratory Trials to Test on Real Application", Proceedings 7th NOLAMP Conference, August 1999.
- [2] Carlsson, T., Palmquist, N., "Nd:YAG Laser Welding of Aluminium Blanks, Utilised Technical Aspects on Weldability and Formability", Proceedings 7th NOLAMP Conference, August 1999.
- [3] Nagel, M, Fischer, R, Löwen, Straube, O., "Production and application of aluminum tailored blanks", Proceedings IBEC'97, 1997.
- [4] Pohl, T., Schultz, M., "Laser beam welding of aluminium alloys for light weight structures using CO₂- and Nd:YAG-laser systems", Proceedings LANE'97, 1997.
- [5] ASM Handbook Volume 6, "Welding, Brazing and Soldering", 1993.
- [6] Larsson, J.K.: "Laser Welding - A Suitable Tool to Help Realizing Light Weight Car Body Structures", Proceedings 6th International Congress of the European Automobile Engineers Cooperation, Cernobbio, Italy, July 1997.
- [7] Larsson, J.K.: "High Power Nd:YAG Laser Welding - A Promising Manufacturing Technique for Future Light Weight Car Bodies", Proceedings 17:e Nordiske Svejsemøde, Copenhagen, Denmark, May 1997.
- [8] Larsson, J.K.: "The Use of Nd:YAG Lasers in Future Automotive Applications", Proceedings LANE'97, Erlangen, Germany, September 1997.

About the authors

Lars-Ola Larsson, M.Sc. Tech. Lic. Mechanical Engineering, has been working for Volvo since 1995. He has worked as a welding engineer at the Product Development Department and was involved in starting up and tuning production of large platform cars (current products S80/V70) at the Volvo Torslanda Plant. Since 1998, he has focused on advanced engineering in the field of joining light-weight materials. In June 2000 he was appointed as manager of the VCC Joining Centre.

Niclas Palmquist, M.Sc. Mechanical Engineering, has been working for Volvo since 1994. After spending four years in Research and Department at the Volvo Technical Centre, he joined the Volvo Car Corporation in 1998, since when he has been working as a research engineer in the fields of laser welding and mechanical joining. Since 1998, he has focused on advanced manufacturing engineering in the field of joining light-weight materials for car bodies.

Johnny K Larsson graduated from the Technical University of Lund, Sweden in 1975. After spending eight years as an engineer in the heavy truck industry, he joined the Volvo Car Corporation in 1986. Acting as a senior car body engineer, he is responsible for the coordination of R&D activities in the Body Engineering Department, covering areas such as materials technology, joining methods, structural analysis and simulations.